

MDM

CABLE MANAGEMENT SYSTEMS

Since 2008

- Cable Trays
- Cable Tray Accessories
- Junction Boxes
- Gratings and its Accessories

An ISO 3834 | IEC 61537 | ISO 9001 Certified Company

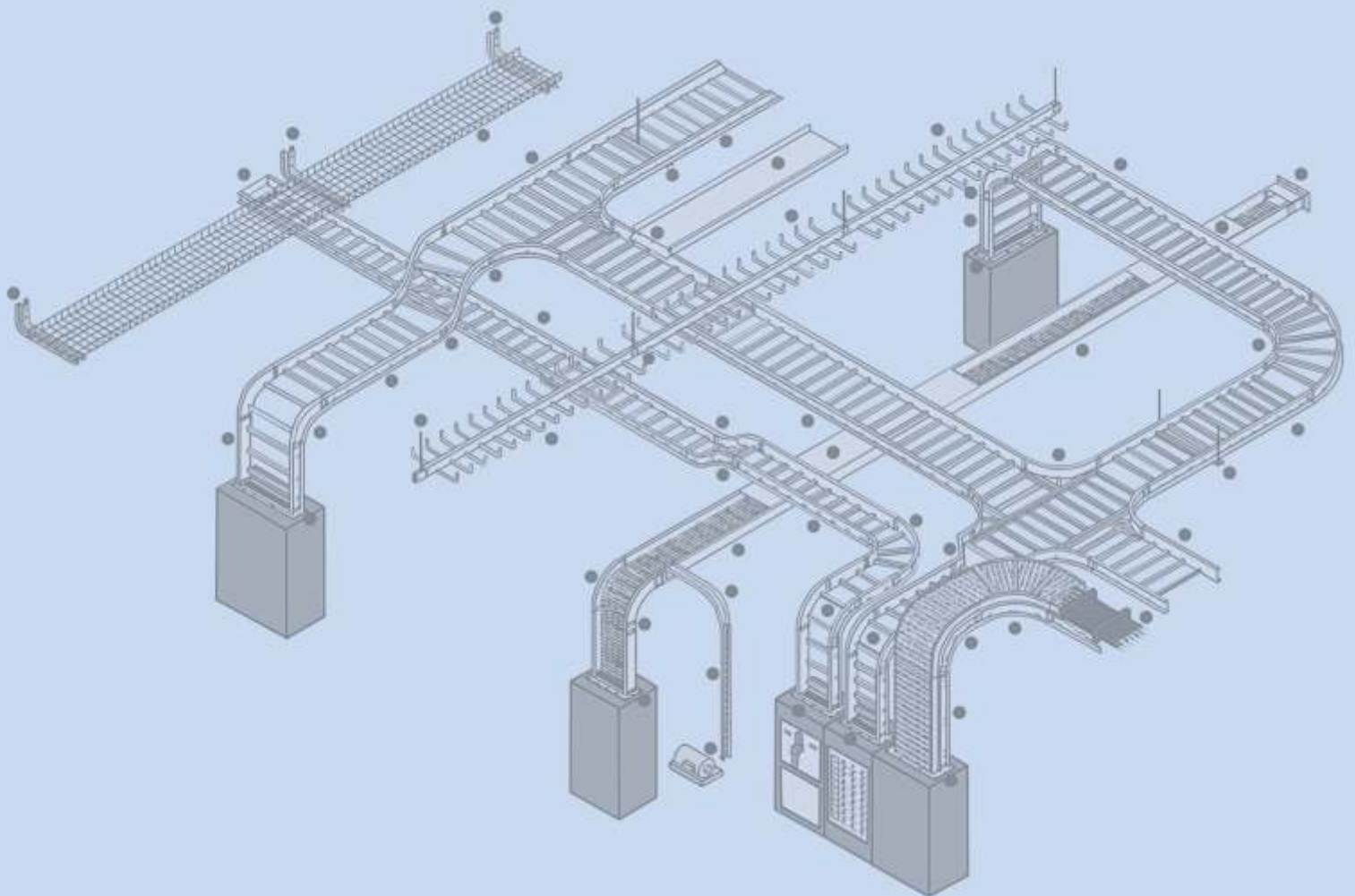

Perforated Cable Trays

Types of Cable Tray based on folding

Straight Type Fold

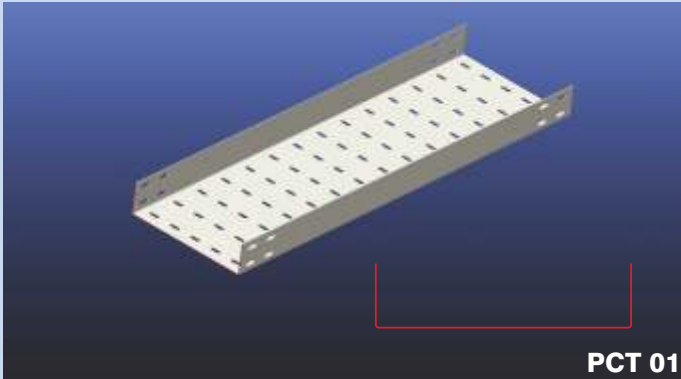

C Type Inside Fold

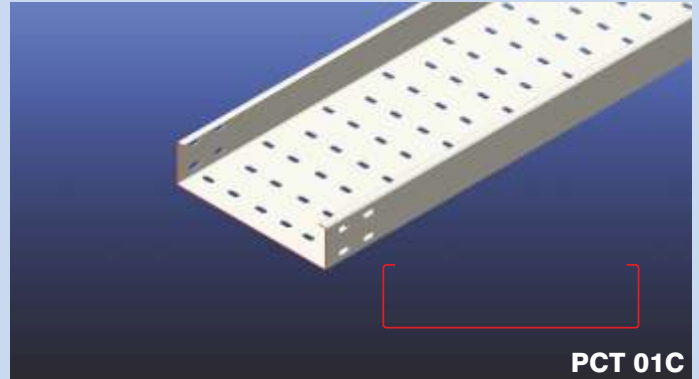

Ladder Type

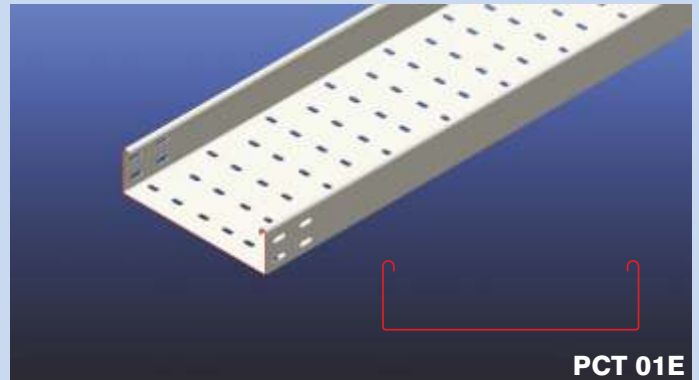
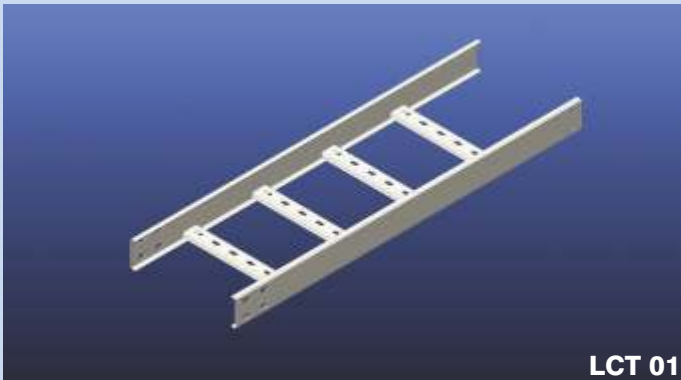

Collapsible Ladder Type

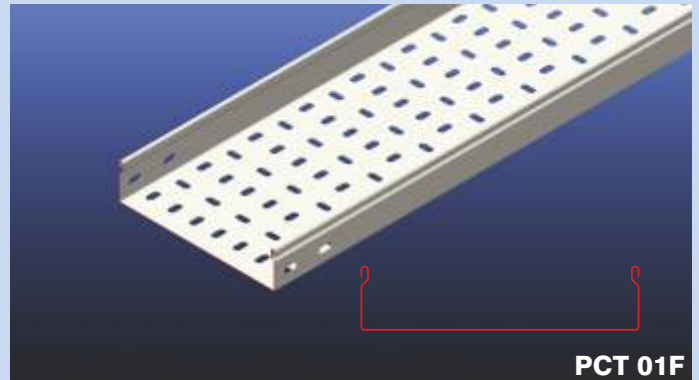
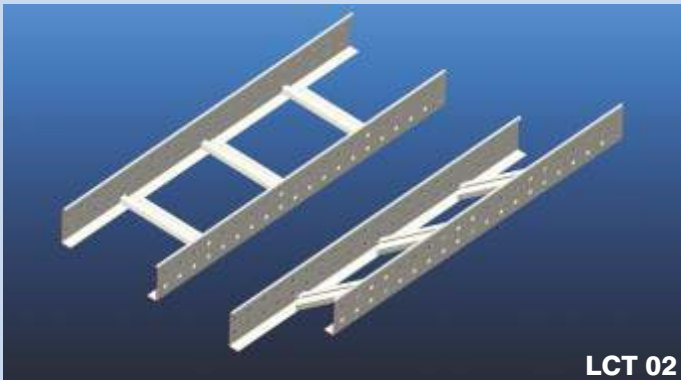

Wiremesh Type

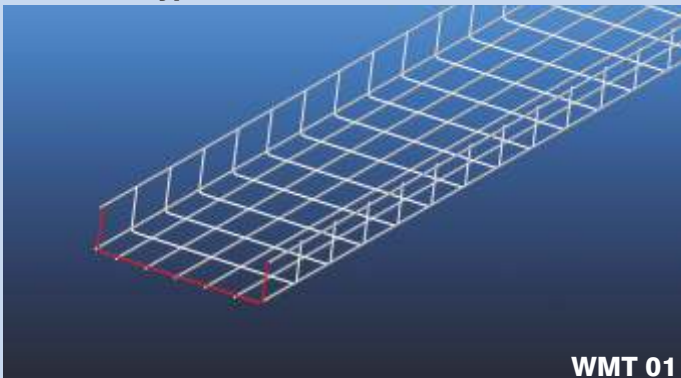

Raceways with Cover

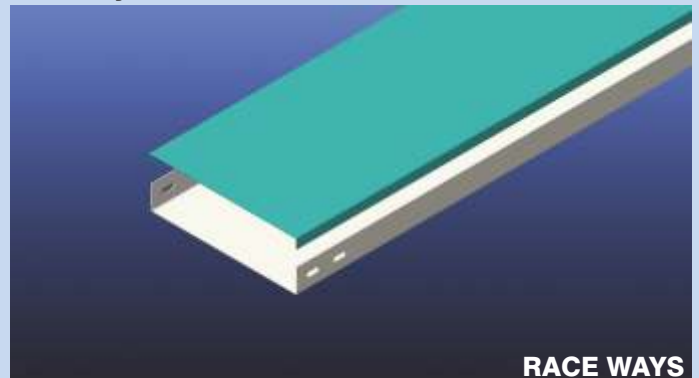

Standard Tray Sizes

(Depending on the finish of the cable trays selection thickness can varies)

Thickness (mm)	Width (mm)	Side height Dimensions (mm)	Available finishes
1	50, 75, 100, 125, 200, 225, 300, 350, 400, 450	13, 25, 50, 75, 100, up to 300	Stainless steel (SS) Aluminium (AL) Pre - Galvanised steel (GI) Hot Dip Galvanised (HDG) Powder coating (PC) Epoxy / Enamel Coating (PA)
1.2	50, 75, 100, 125, 200, 225, 300, 350, 400, 450	13, 25, 50, 75, 100, up to 300	
1.6	50, 75, 100, 125, 200, 225, 300, 350, 400, 450, 500, 550, 600, 650	13, 25, 50, 75, 100, up to 300	
2	50, 75, 100, 125, 200, 225, 300, 350, 400, 450, 550, 600, 650, 700, 750, 800, 850, 900, 950, 1000	13, 25, 50, 75, 100, up to 300	
2.5	50, 75, 100, 125, 200, 225, 300, 350, 400, 450, 550, 600, 650, 700, 750, 800, 850, 900, 950, 1000	13, 25, 50, 75, 100, up to 300	
3	50, 75, 100, 125, 200, 225, 300, 350, 400, 450, 550, 600, 650, 700,	13, 25, 50, 75, 100, up to 300	

Perforated Type Accessories

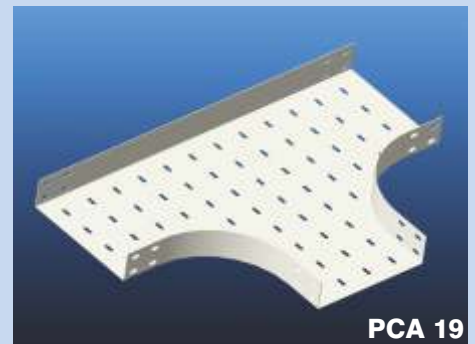
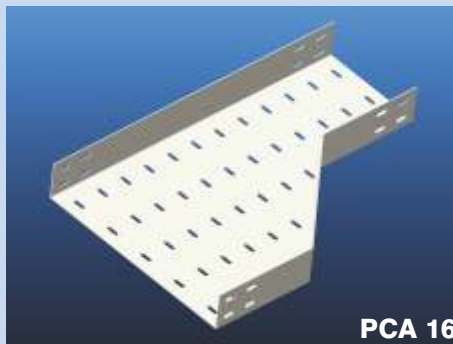
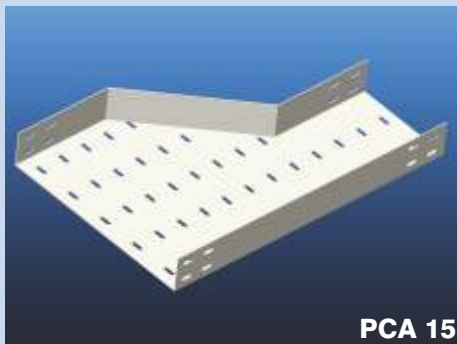
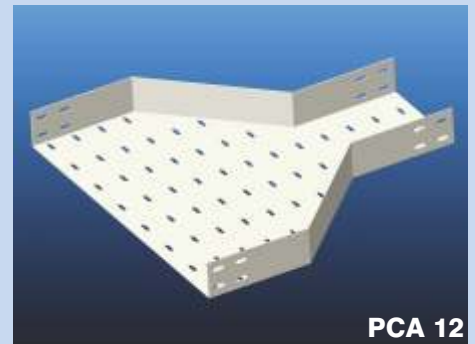
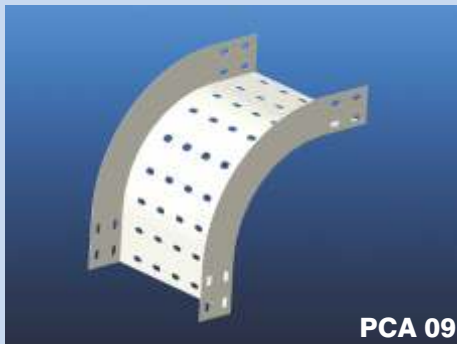
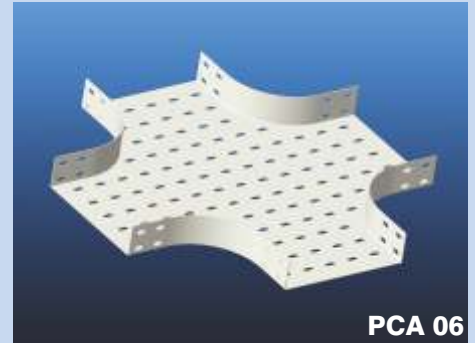
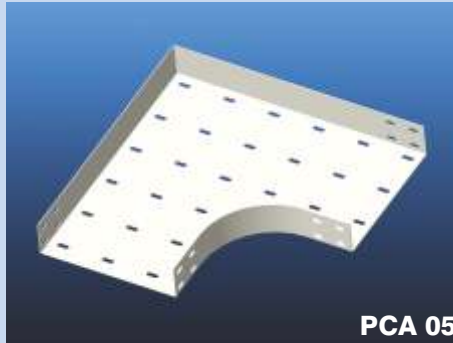
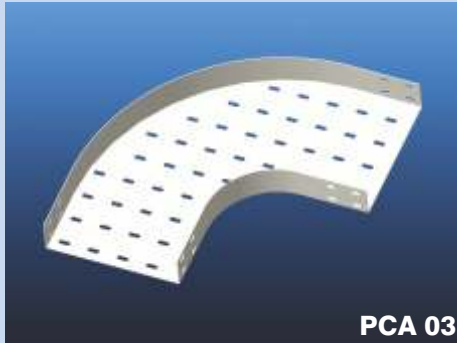

Ladder Tray Accessories

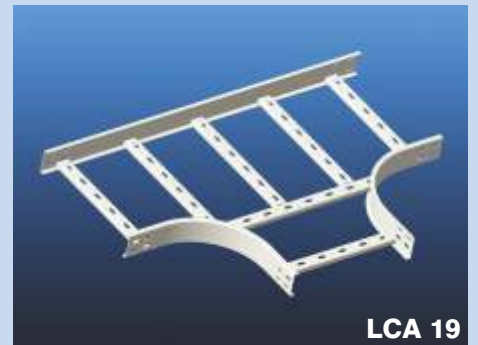
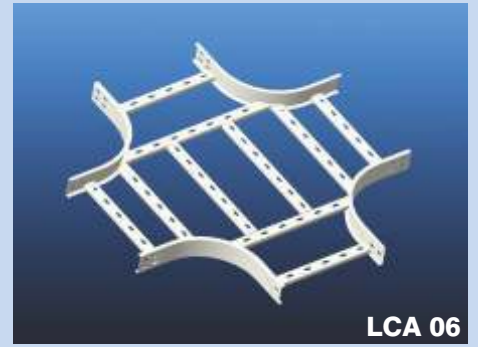
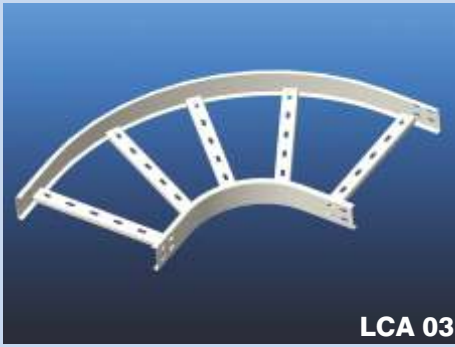

Why MDM?

- * Our company strictly follows QMS, and we strongly believe that "if we take care of the system, the system takes care of us."
- * Fully automated CNC manufacturing facility for cable trays and ensures premium and precise quality, shorter lead times, and easy repeatability.
- * One Stop Solution for all types of Cable Trays, Conduits, Junction Boxes and its accessories.
- * Successfully supplied over 7 lakh kilometers of cable trays in the last 16 years, and having a strong delighted customer base.
- * Successfully supplied cable trays for over 10,000 coaches to M/s. ICF, Chennai, and many others. Over more than 10 years of business, we have demonstrated our commitment to quality and reliability in manufacturing and supply.



Gratings

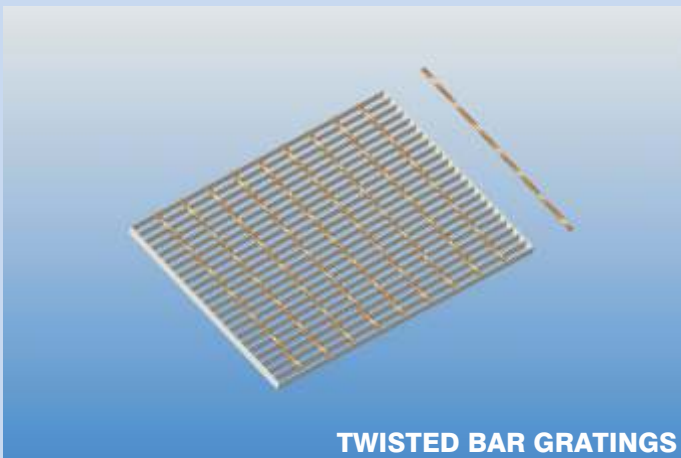
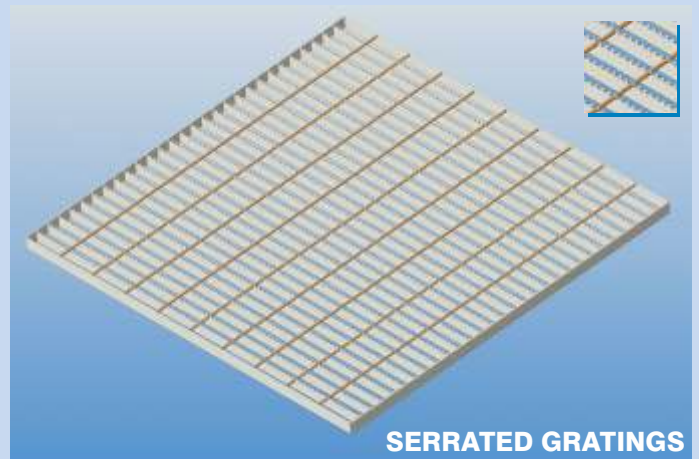
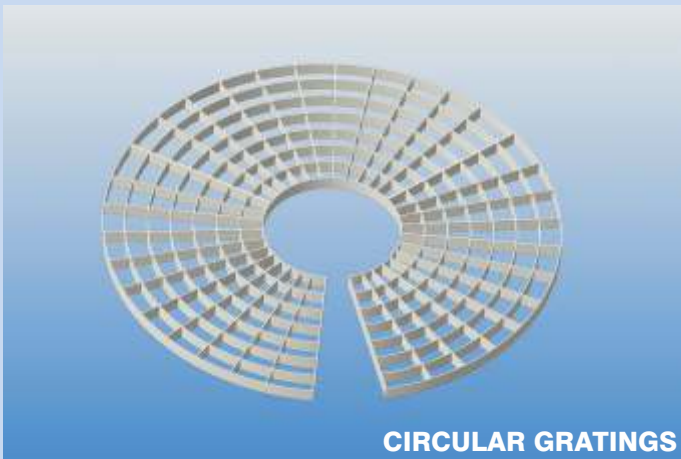
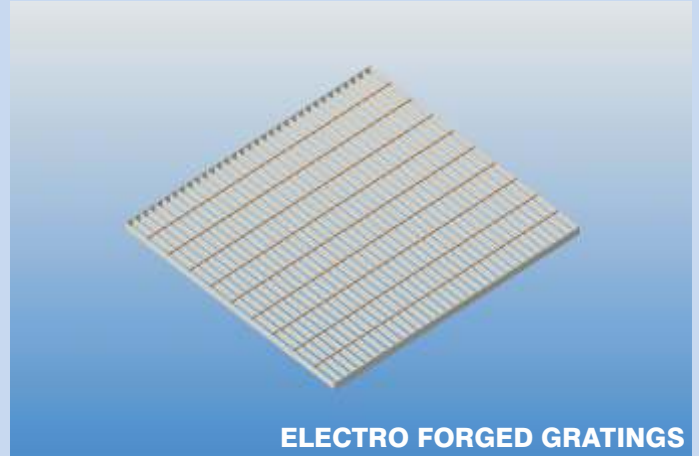
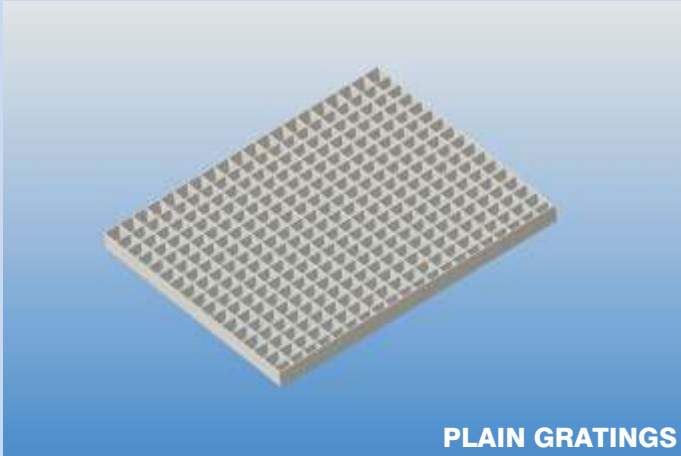

Types of Gratings we manufacture:

- Electro Forged Steel Gratings
- Manual Welded Steel Gratings
- Press locked Steel Gratings
- Aluminium Gratings
- Stainless Steel Gratings
- FRP / GRP Gratings
- Stair Treads / Grating Accessories

GRATINGS ACCESSORIES

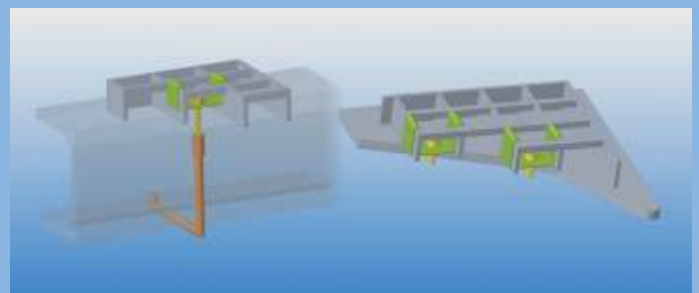
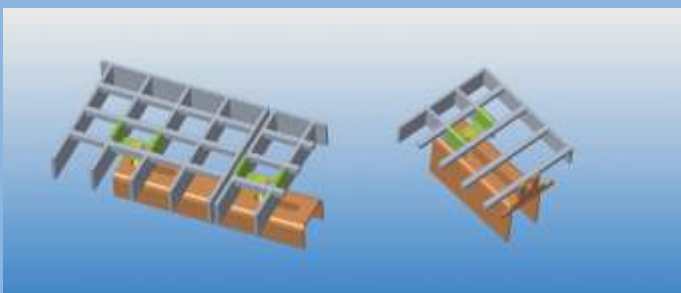

Hardwares & Associated Accessories



End Cover



Strut

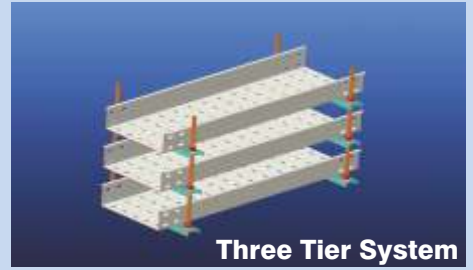

Three Tier System



Tray to Control Panel Connector

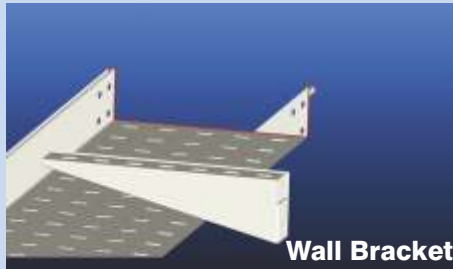

Wall Bracket



Wall Frame



Wall Bracket



Wall Bracket



Wire Mesh Accessories



Pop Rivet



Bolt & Nuts



Thread Rods



GI & Flexible Conduits & Junction Box

House of Automated CNC Machines



CNC Turret Punching Machine
- Muratec, Japan

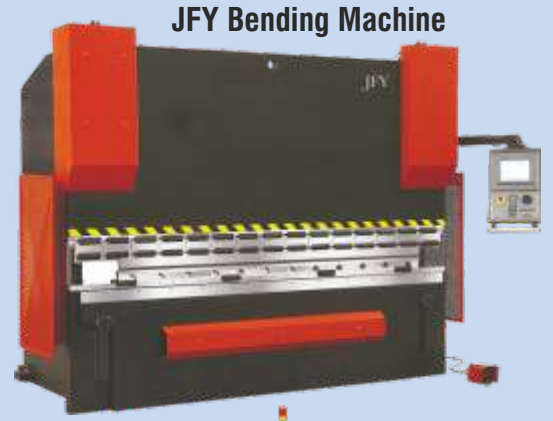

JFY Bending Machine



Laser Cutting Machine - 3 kw

OUR VALUABLE



CUSTOMERS

MDM Engineering and Technologies

No.4, PKM Road, Padasalai Street, Ayanambakkam, Chennai - 600 095. INDIA

email: sales@mdmtech.in, md@mdmtech.in | Web : www.mdmtech.in

Mobile : 8220078555 | 9840184858

